

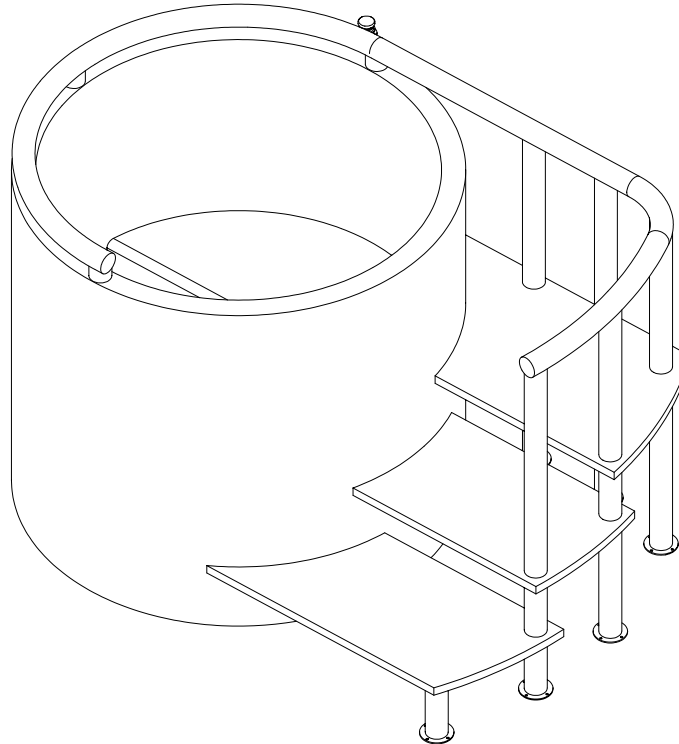

SOHO MASSAGE AIR JET BATH INSTALLATION AND OPERATING INSTRUCTIONS



MODEL # 8973-JET

OWNER'S RECORD	
Date Purchased:	_____
Purchased From:	_____
Installed By:	_____
Serial Number:	_____

**IMPORTANT: READ COMPLETE INSTRUCTIONS
BEFORE BEGINNING INSTALLATION!**

Field Service Telephone Number: 800.743.8259
NEO-METRO Collection • P.O. Box 3527 • City of Industry, CA 91744 USA
Tel # (800) 591-9050 / (626) 855-4854 • Fax # (626) 937-4725
Web Site: www.neo-metro.com

IMPORTANT INFORMATION

 **WARNING:** Always follow basic precautions when using electrical products including, but not limited to, the following:

 **DANGER: Risk of electric shock.** Connect only to a circuit protected by a Ground-Fault Circuit-Interrupter (GFCI).

 **WARNING: Risk of electrical shock.** A licensed electrician should make all electrical connections.

 **WARNING: Risk of electrical shock.** Disconnect power before servicing.

 **WARNING: Risk of injury or property damage.** Please read all instructions thoroughly before beginning installation, including the following requirements.

NOTICE:

- Follow all local plumbing and electrical codes.
- Install unit as to permit future access for servicing.
- Building materials and wiring should be routed away from the blower motor assembly.
- Grounding is required. The unit should be installed by a qualified service representative, and grounded.
- The minimal structural strength of the floor beneath the unit shall be 600 pounds per square foot or 4.2 pounds per square inch.

ELECTRICAL REQUIREMENTS

The installation must have a Class A Ground-Fault Circuit-Interrupter (GFCI). The GFCI protects against line-to-ground shock hazard. Use 120 Volts, 60 Hertz, 15 Amp dedicated service for the tub.

CONNECTIONS AND SERVICE ACCESS

Before installation, ensure proper access to the final connections. **NOTICE: Provide unrestricted service access to the blower motor and controls.** You must provide a minimum 18" clearance behind access panels for panel removal and access to internal components. Study the roughing-in information shown in this manual.

PRODUCT NOTICES

 **WARNING: Unauthorized modification may cause unsafe operation and poor performance for the tub.** Do not relocate the tub blower motor, or make other modifications to the tub system, as this could adversely affect the performance and safe operation of the fixture. Acorn Engineering Company shall not be liable under its warranty or otherwise for personal injury or damage caused by any such unauthorized modification.

IMPORTANT:

- The heating element on your air massage system is designed to preheat the air blown into the bathtub to body temperature, to prevent the water from cooling too fast. It will not, under any circumstances, heat, reheat or maintain the temperature of the bathwater.
- Use this unit only for its intended use as described in this manual. **Do not** use attachments not recommended by NEO-METRO.
- Never drop or insert any object into the unit's massage air jet openings.
- Air jet action can cause even a small amount of bubble bath, bath soap, shampoo, or bath oil to foam excessively. Refrain from using these products during air jet blower motor operation.
- Flush and clean your Soho tub system before first use, and twice a month or more depending upon usage, as per the Cleaning Guidelines on Pages 14 and 15.

IMPORTANT SAFETY INSTRUCTIONS
READ AND FOLLOW ALL INSTRUCTIONS

SAVE THESE INSTRUCTIONS

**INSTRUCTIONS PERTAINING TO A RISK OF FIRE, ELECTRIC SHOCK,
OR INJURY TO PERSONS**

 **WARNING:** ALWAYS FOLLOW BASIC PRECAUTIONS WHEN USING THIS UNIT INCLUDING, BUT NOT LIMITED TO, THE FOLLOWING:

 **DANGER:** Risk of accidental injury or drowning; Children should NOT use massage jet bath without CONSTANT ATTENTIVE adult supervision.

 **WARNING:** To avoid injury, exercise caution when entering, exiting or moving around in the massage jet bath. Wet surfaces are inherently slippery when wet.

 **WARNING:** Risk of electrical shock; do not permit electrical appliances (such as hair dryer, lamp, telephone, radio or television) within 60" (1.5 M) of this massage jet bath.

 **DANGER:** Risk of personal injury. Hot massage jet bath can stress the body, as does any hot bath, shower, sauna, or steam bath. **Prolonged immersion in hot water may induce hyperthermia.** Symptoms of hyperthermia include an increase in the internal body temperature, dizziness, lethargy, drowsiness, and fainting. The effects of hyperthermia include (1) failure to perceive heat, (2) failure to recognize the need to exit the bath, (3) unawareness of impending hazard, (4) fetal damage in pregnant women, (5) physical inability to exit the bath, and (6) unconsciousness resulting in danger of drowning.

 **WARNING:** Risk of fetal injury; pregnant or possibly pregnant women should consult a physician before using a massage jet bath.

 **WARNING:** Risk of fatal hyperthermia; people using medications and/or having an adverse medical history should consult a physician before using a massage jet bath.

 **WARNING:** Risk of hyperthermia, accidental injury or drowning; DO NOT use drugs or alcohol before or during the use of massage jet bath to avoid unconsciousness and possible drowning.

 **WARNING:** Risk of hyperthermia, accidental injury or drowning; DO NOT use a massage jet bath immediately following strenuous exercise.

 **WARNING:** Risk of hyperthermia and possible drowning; water temperature in excess of 100° F (38° C) may be injurious to your health. **DO NOT** allow water temperature in unit above 100° F (38° C). Check and adjust water temperature before use.

FIXTURE IS PROVIDED WITH A 3-WAY PLUG TO REDUCE THE RISK OF ELECTRIC SHOCK. THE THIRD PRONG FUNCTIONS AS A BUILT-IN GROUND AND MUST BE PLUGGED INTO A MATCHING GROUNDING TYPE RECEPTACLE TO PROPERLY GROUND THE PRODUCT PER N.E.C. (NATIONAL ELECTRICAL CODE). CONNECT ONLY TO A SUPPLY CIRCUIT PROTECTED BY A GROUND-FAULT CIRCUIT-INTERRUPTER (GFCI). IN CANADA, INSTALL THIS UNIT IN ACCORDANCE WITH THE CANADIAN ELECTRICAL CODE, PART 1. **DO NOT REMOVE THE PLUG GROUND PIN. DO NOT USE GROUNDING ADAPTERS.**

⚠ CAUTION: Test the installer provided Ground-Fault Circuit-Interrupter (GFCI) protecting this appliance periodically in accordance with manufacturer’s instructions. Depressing GFCI test button should interrupt power. Power should be restored depressing reset button. If the test fails, GFCI is defective. If the GFCI interrupts power to the unit without the test button being pushed, a ground current is flowing. In either case, this indicates that **ELECTRICAL SHOCK IS POSSIBLE: DO NOT USE THIS UNIT.** Disconnect the power supply and have the problem corrected by a qualified electrician before using.

Note: This is a professional grade product. A knowledge of construction techniques, plumbing and electrical installation according to codes are required for proper installation and user satisfaction. We recommend that a licensed contractor perform the installation of all Neo-Metro Collection products. Our warranty does not cover improper installation related problems.

**PRODUCT SPECIFICATIONS ARE SUBJECT TO CHANGE WITHOUT NOTICE.
USE INSTALLATION INSTRUCTIONS SUPPLIED WITH PRODUCT.**

TABLE OF CONTENTS

BEFORE YOU BEGIN: WARNINGS AND PRECAUTIONS	2, 3, & 4
SITE PREPARATION: FRAMING AND SUPPORT	5
SERVICE ACCESS REQUIREMENTS	6
ELECTRICAL REQUIREMENTS	7
ROUGHING-IN INFORMATION	8 & 9
INSTALLATION INSTRUCTIONS	10 & 11
OPERATING INSTRUCTIONS	11 & 12
TROUBLE SHOOTING PROBLEMS	13
CLEANING GUIDELINES	14 & 15
LIMITED WARRANTY	16

SITE PREPARATION: FRAMING AND SUPPORT

Prepare fixture location with consideration to overall dimensions, drain location and service access areas. The floor structure beneath the tub must be able to support the total weight of the fixture, water and user.

TOP VIEW

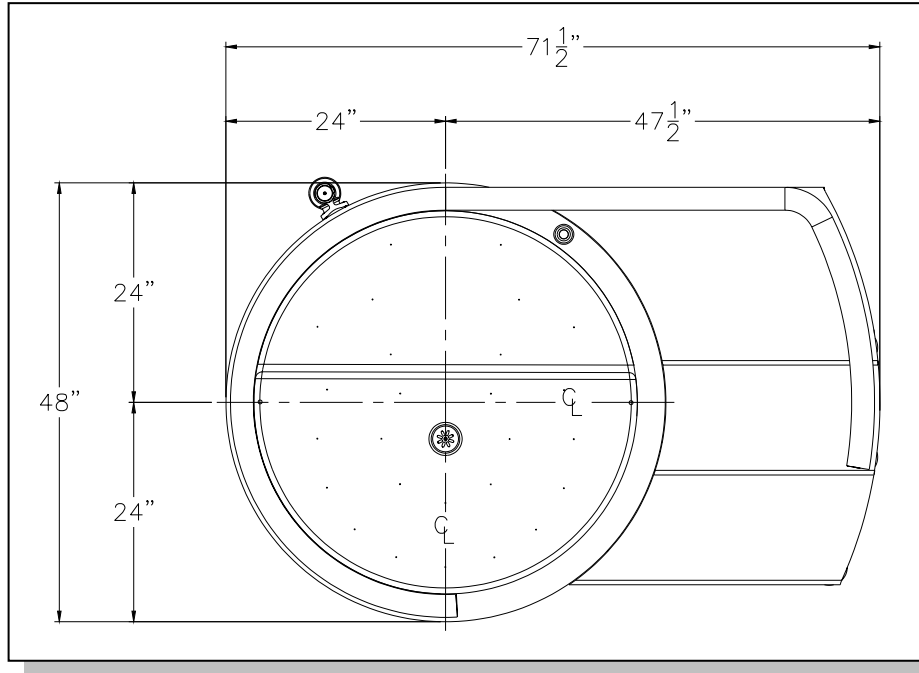

If the floor or sub floor is level, no other preparation is necessary. If the floor or sub floor is not level, you **MUST** level the entire surface prior to installation. The tub must remain level in order to drain properly. Both sides of a joint or splice of floor or sub floor should be level to each other.

SIDE VIEW

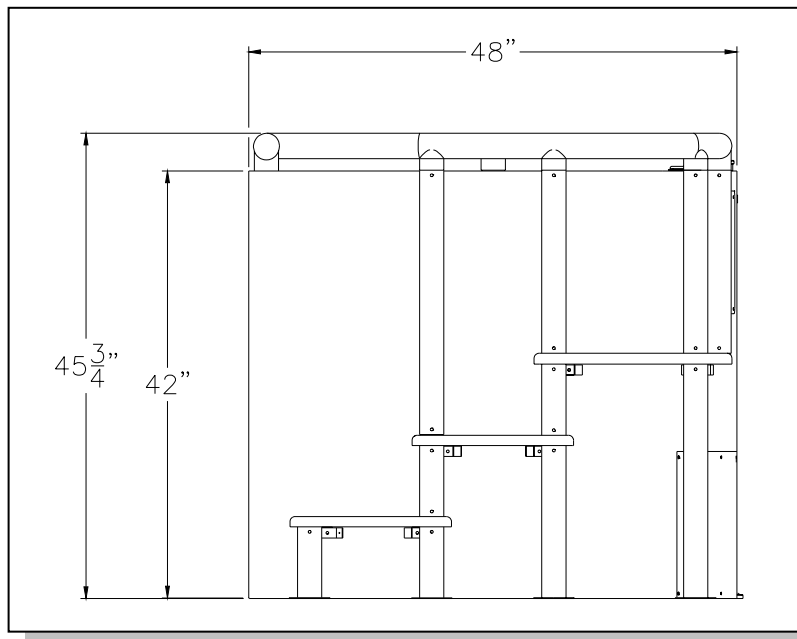

SERVICE ACCESS REQUIREMENTS

The recommended minimum dimension allowable for service access to the fixture and stair / railing assembly is 18".

SERVICE ACCESS AREA

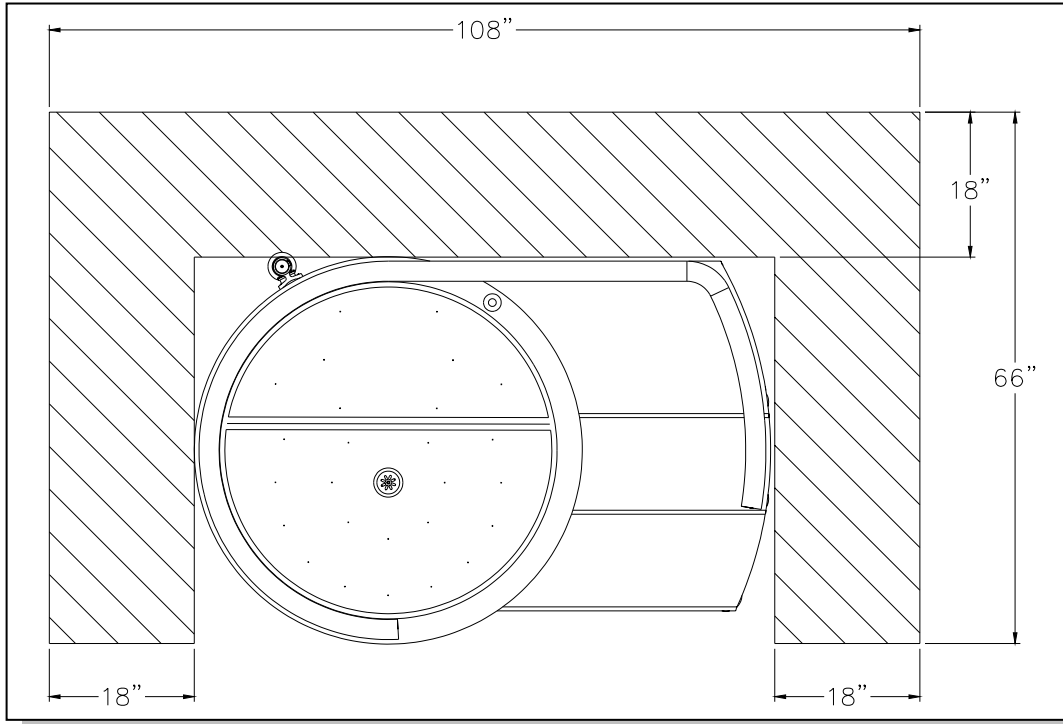

Anchoring of fixture, pump installation and waste connections are thru the lower access panel, it is the installer's responsibility to provide sufficient service access.

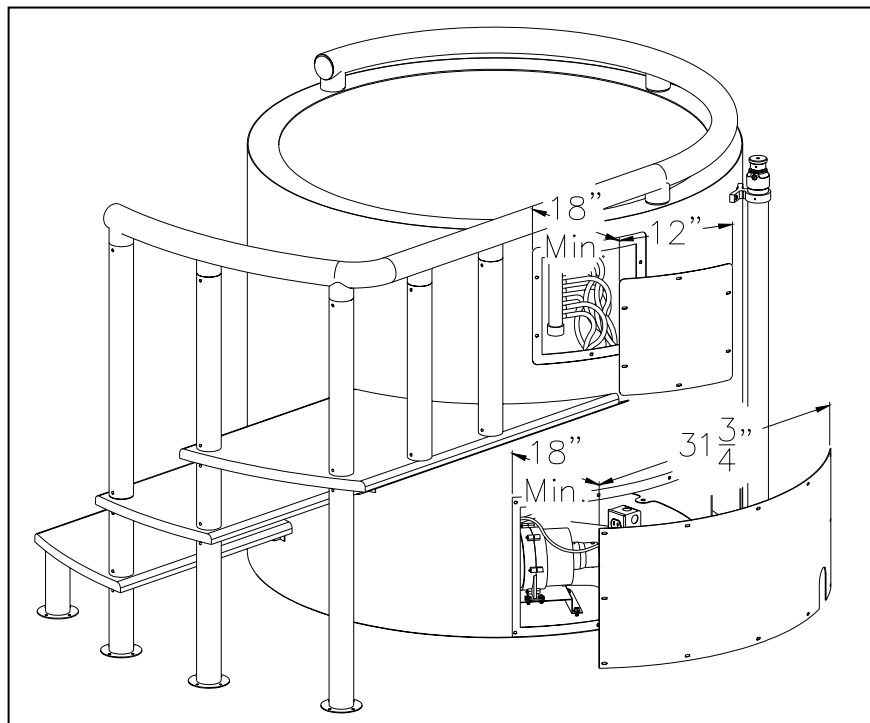

ELECTRICAL REQUIREMENTS

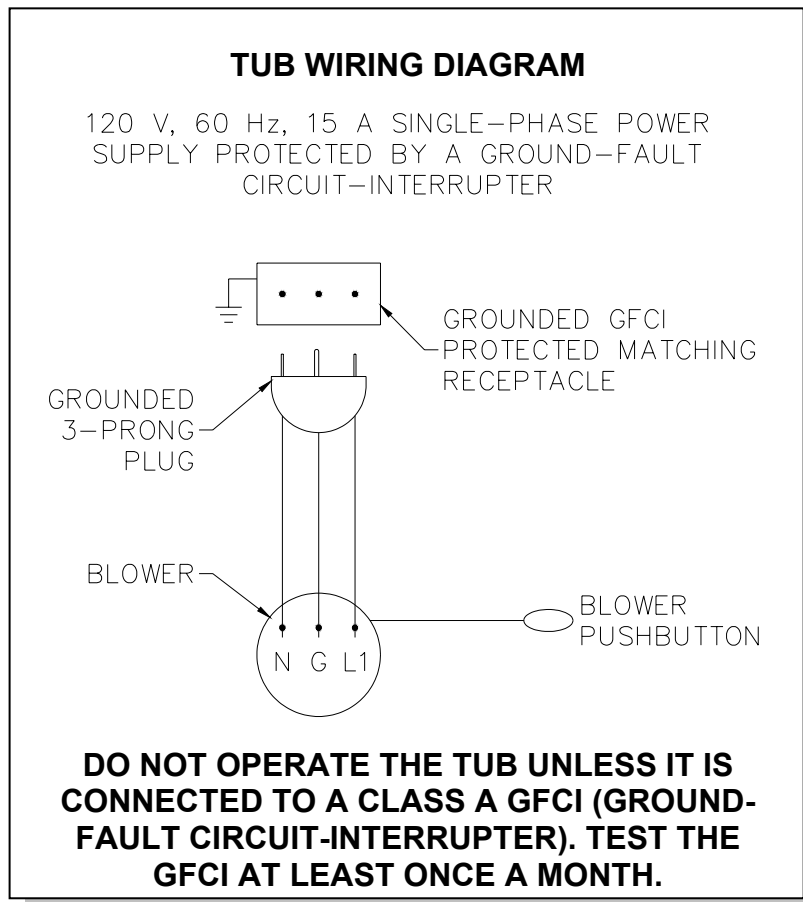

The blower assembly is rated at 120 Volts, 60 Hertz, 9.5 Amps and comes equipped with a grounded 3-prong plug, which must be connected into a matching grounded receptacle, supplied by others, per N.E.C. (National Electrical Code). The unit must only be connected to a separate, independent 120 V, 60 Hz, 15 A circuit supply that is protected by a Ground-Fault Circuit-Interrupter (GFCI). The grounded receptacle (by others) must be installed at least 4" above the finished floor.



DANGER: RISK OF ELECTRICAL SHOCK. Connect only to a circuit protected by a Ground-Fault Circuit-Interrupter (GFCI).

For Installations in Canada:

The electrical installation is subject to inspection and approval by the local inspection authority. Employ a licensed electrician to connect the equipment to the supply in accordance with the local electrical code. Check that the power available corresponds to that required by the motor.

The tub must be connected to a separate 120 VAC, 15 AMP, single-phase circuit supply. Note that the protection of the circuit by a ground fault circuit interrupter is mandatory under the Canadian Electrical Code, Part 1, Section 68. Ground fault circuit interrupters are available from your local electrical supplier.

ROUGHING-IN INFORMATION

IMPORTANT: Proper installation of plumbing and compliance to local codes are the responsibility of the installer. Neo-Metro is not responsible for damage to the tub that may occur during installation.

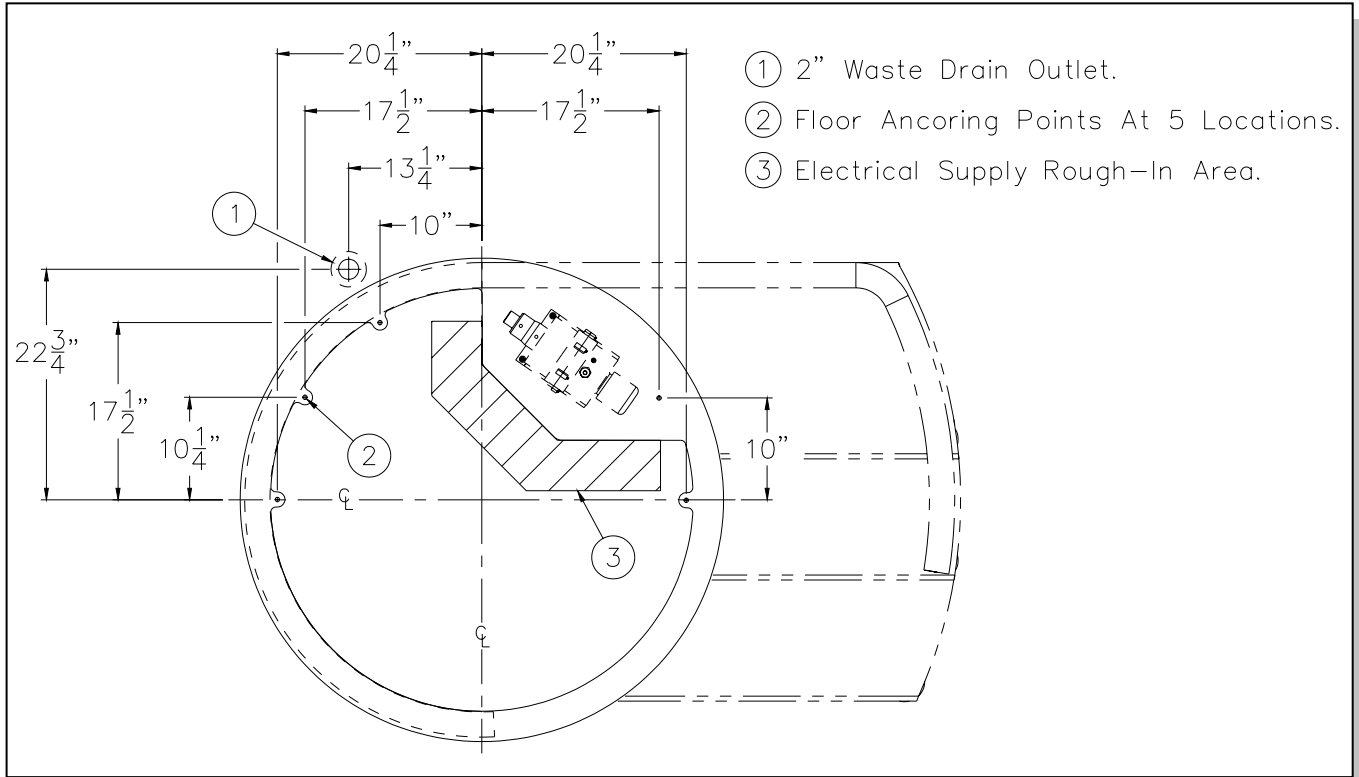

Rough-in for 2" waste outlet located at dimensions shown (item #1).

Rough-in for tub floor anchoring points (5 locations) at dimensions shown (item #2). Use 3/8" Floor anchors and anchoring hardware by others.

RAIL POST BASE DETAIL

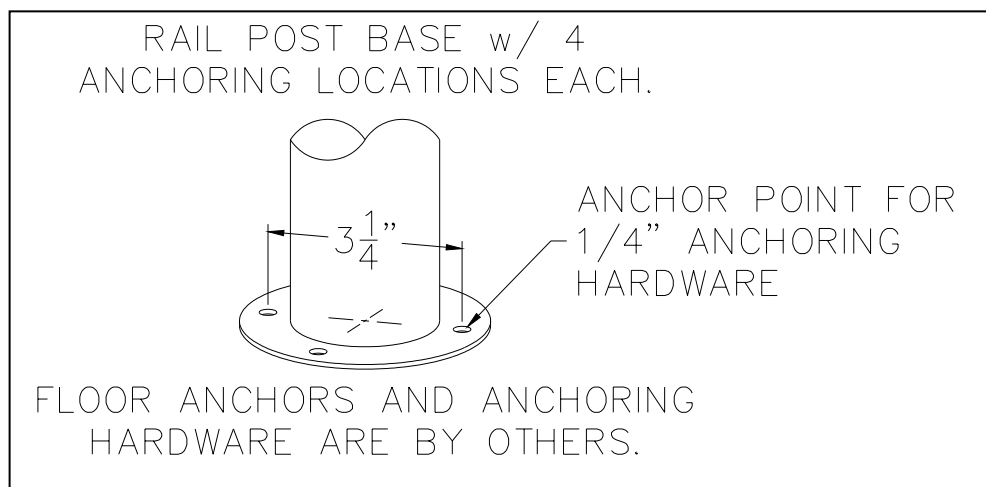

ROUGHING-IN INFORMATION (Continued)

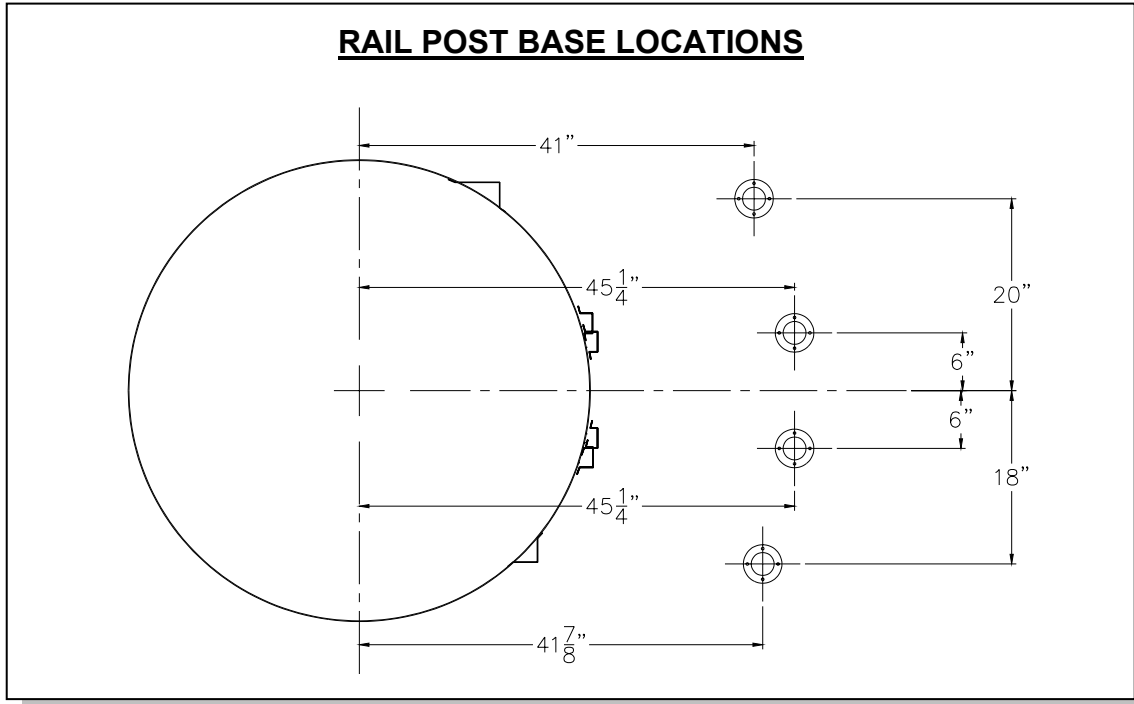

Rough-in for anchoring points of stair / railing assembly. Use rail post bases as a template to locate and install appropriate floor anchors for 1/4" anchoring hardware. Floor anchors and anchoring hardware are by others.

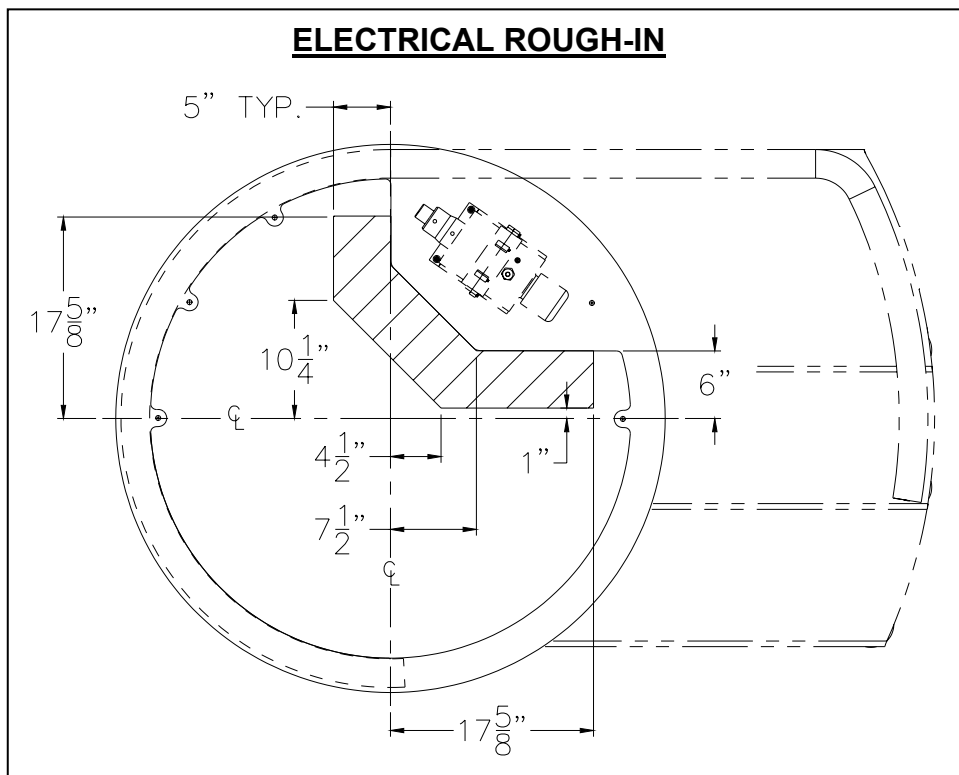

Rough-in for 120 V, 60 Hz Ground Fault Circuit Interrupter (GFCI) protected electrical supply receptacle by others in the area shown. The electrical supply must be on a separate supply circuit protected by a GFCI. Install the supply receptacle by others at least 4" above finished floor.

INSTALLATION INSTRUCTIONS

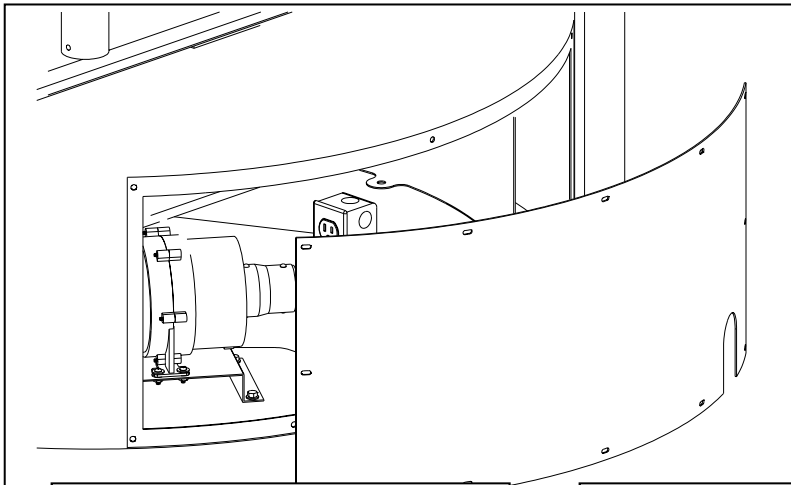

Remove lower access panel.

Set fixture into position ensuring drain/overflow assembly aligns with 2" drain outlet and floor-anchoring points align with installer provided floor anchors.

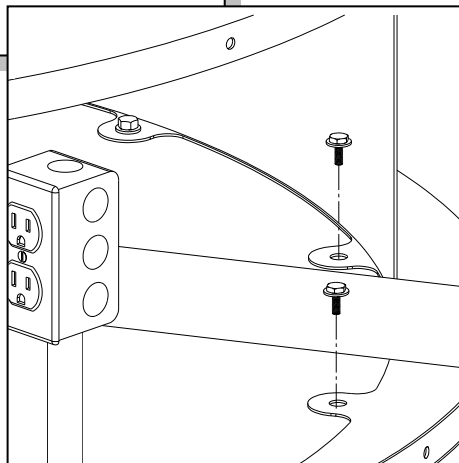
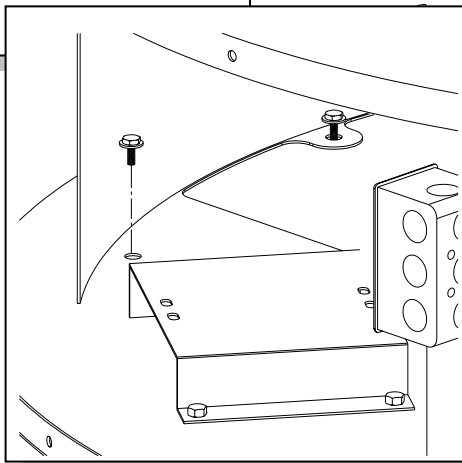

Fasten all five (5) anchoring points thru lower access area with installer provided anchoring hardware

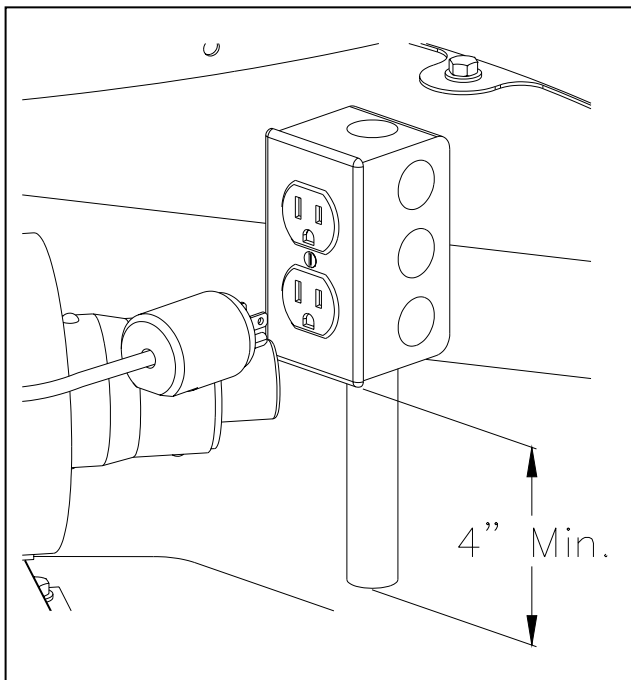

Connect 3-prong blower plug to separate GFCI protected 120 V, 60 Hz electrical supply receptacle (by others).



DANGER: RISK OF ELECTRICAL SHOCK. Connect only to a circuit protected by a Ground Fault Circuit Interrupter.

INSTALLATION INSTRUCTIONS (Continued)

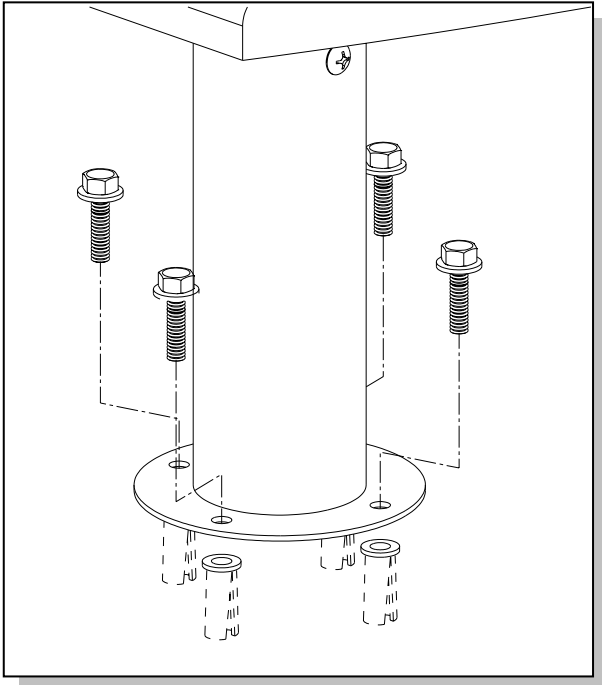

Align holes in the rail post bases with floor anchors provided by installer. Anchor through bases with anchoring hardware provided by installer completing installation.

IMPORTANT: Area underneath and around the tub must be cleaned before finalizing the installation to ensure that no construction debris, wood shavings or other particles enter into the air blower and are blown through the jets. Also clean out the tub itself.

NOTE: Test for leaks and proper operation of fixture prior to re-installing lower access panel. Refer to the Operating Instructions in this manual.

OPERATING INSTRUCTIONS

IMPORTANT: Clean fixture thoroughly following guidelines in this manual prior to first operation of unit. If necessary, use a vacuum cleaner to remove all dirt and installation debris.

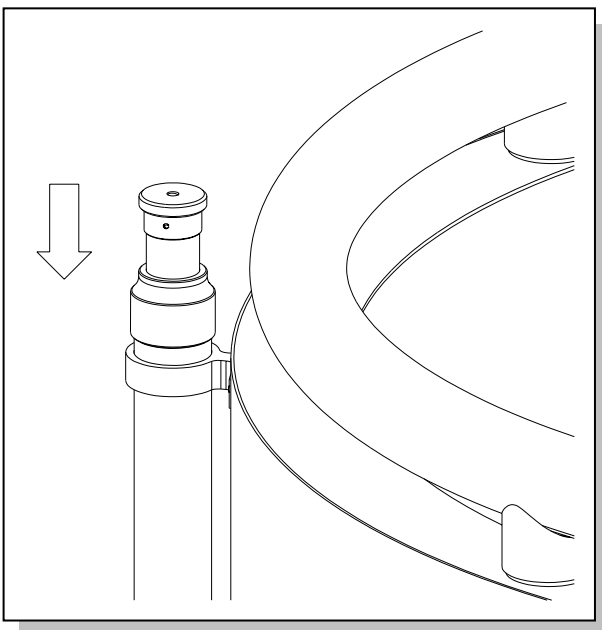

Close tub drain by pushing plunger on overflow assembly down.

Fill tub using faucet and spout by others with water to level no more than 7" below the rim including the bather. Overflow is at 5" below the rim. Never fill the tub with water above the overflow level.

⚠ WARNING: Risk of hyperthermia and possible drowning; water temperature in excess of 100° F (38° C) may be injurious to your health. **DO NOT** allow water temperature in unit above 100° F (38° C). Check and adjust water temperature before use.

OPERATING INSTRUCTIONS (Continued)

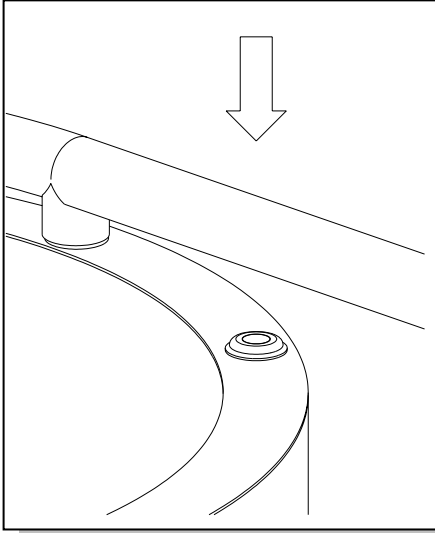

Activate air massage jets by depressing blower pushbutton on tub rim. Three speed blower motor functions as follows:

Depress Button	Air Jet Speed
Once	High
Twice	Medium
Three Times	Low
Four Times	Off

Note: Blower will automatically turn off after 20 minutes of continuous operation.

IMPORTANT: The blower has an automatic drying cycle. 20 minutes after blower is turned off, the 1 minute drying cycle will automatically commence. The 20 minute delay prior to the drying cycle is to allow for draining of the tub. If for any reason, the bathwater was not drained after the 20 minute delay, the system **MUST** be activated manually for 1 minute in order to dry the air jets after having drained the bathwater.

To drain tub, lift plunger on overflow assembly allowing used bathwater to escape. Rub tub down to dry it and clean it if necessary following cleaning guidelines in this manual.

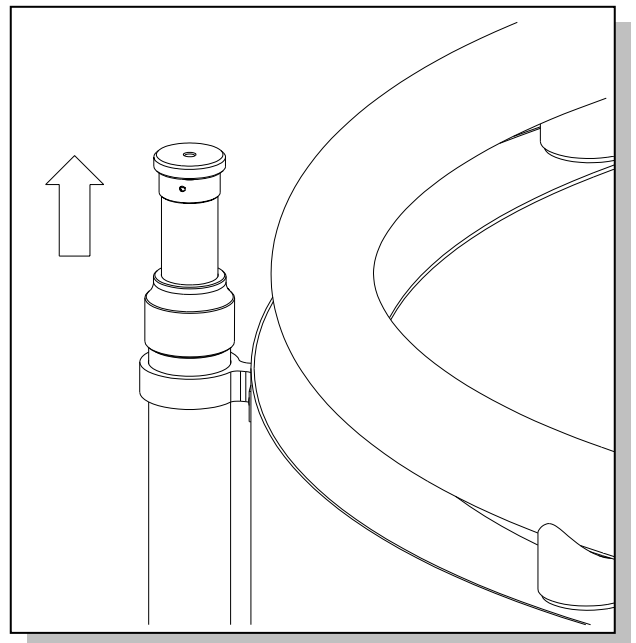

TROUBLE SHOOTING

CONDITION	PROBABLE SOLUTION
The air blower starts on its own.	<ol style="list-style-type: none"> 1. Could be normal drying cycle. 2. Drying cycle potentially triggered by power outage. 3. If happens repeatedly without previous use, control pushbutton might require replacement.
The drying cycle does not come on.	Verify power has not been discontinued to unit.
I can hear the blower working but no air comes through the jets.	Verify that air hoses are properly connected.
I can hear the blower working but not all jets are working.	<p>This is caused when the jets are clogged with either installation debris or calcium accumulation. To solve this, simply do the following:</p> <ol style="list-style-type: none"> 1. fill the tub with enough hot water to cover all the bottom jets; 2. turn on system and let function for one full minute; 3. While the system is in function, locate exactly which jets are not working and gently tap on the top of the jet covers with the plastic end of a screwdriver or a small rubber hammer.
My blower works but stops after 10-15 minutes.	<p>The blower is equipped with a thermo protector. If the blower should overheat for any reason, it will automatically shut down.</p> <ol style="list-style-type: none"> 1. Allow system to cool for approximately 1 to 1-1/2 hours; 2. Check that the blower has not been insulated and that surrounding air circulation is sufficient.
I press the air pushbutton but the unit will not start or stop.	<ol style="list-style-type: none"> 1. If you press the button and it is either hard to press or slow to rise there is simply an air accumulation in the hose: <ol style="list-style-type: none"> a. Verify that pushbutton hose is not kinked or bent preventing the air passage. b. Pierce one or two small holes with a small pin in pushbutton hose to allow air to evacuate. 2. If the button is easy to press and easy to rise, disconnect pushbutton hose and blow gently into it. <ol style="list-style-type: none"> a. If the blower starts, then pushbutton needs replacing. b. If the blower does not start, then the blower needs to be serviced or replaced.
Nothing seems to work.	Unit is tested before it is shipped. Chances that it does not work at all are slight to none. Therefore, simply shut off the breaker, wait 15 seconds and turn back on. Normally, this should solve your problem
My GFCI keeps tripping.	<ol style="list-style-type: none"> 1. Verify unit is connected to an independent GFCI breaker. 2. Sometimes the GFCI breaker is too sensitive. If the GFCI trips, disconnect the blower and connect a light or a hair dryer. If the GFCI trips again, there is an electrical short somewhere along the line. Have this checked by your electrician. If the problem persists again, the GFCI breaker will have to be changed.

CLEANING GUIDELINES

Stainless steel should be kept clean at all times. If maintained, stainless steel surfaces will retain their new, clean, polished appearance indefinitely.

NORMAL CLEANING

Clean weekly or more often as needed (especially high-polish surfaces).

RECOMMENDED CLEANING MATERIALS:

- Sponge - natural or artificial
- Nylon or other soft-bristle material brush
- **SOFT** cloth (as used on automobile finishes)
- E-cloth with water only (available through NEO-METRO)

RECOMMENDED CLEANING SOLUTIONS:

- Hand dishwashing liquid/soft water solution
- Mild soap/soft water solution
- 3M Stainless Steel Cleaner/Polish
- White vinegar/soft water solution (for brightening, removing oil deposit and hard water deposits)
- CLR Brand Cleaner or baking soda/soft water solution (for brightening, removing hard water deposits)
- Club soda and sponge

FOR HIGH POLISH FINISH

Note: High polish stainless steel surfaces should never come into contact with any abrasive cleaning brush, cloth or cleaning agent.

To remove smudges and fingerprints:

Wipe surfaces with a quality Stainless Steel Cleaner / Polish. Apply using a soft nonabrasive cloth. Always follow cleaner/polish product directions provided.

To remove dirt and debris:

Wash surfaces with a mild liquid soap. Apply using a soft, nonabrasive cloth. Rinse surfaces thoroughly with clean water. Afterwards, using a soft nonabrasive cloth, wipe surfaces with stainless steel cleaner/polish.

To remove rust stains:

Wipe surfaces with CRES (available through NEO-METRO) or equivalent cleaner. Use recommended solutions. Apply using a soft nonabrasive sponge. Rinse surfaces thoroughly immediately after application. Always follow cleaner product directions provided. Afterwards, using a soft, nonabrasive cloth, wipe surfaces with stainless steel cleaner/polish.

FOR TOUGH PROBLEMS

- CRES Cleaner specifically for rust stains (Available through Acorn/Neo-Metro)
- Tarn-X for general stains
- #7 chrome polish
- Silver polish

To remove stubborn spots or to treat a scratch (Standard Satin Finish Only):

Use of synthetic, abrasive, general-purpose pads such as Scotch Brite® is recommended. Apply the stainless steel cleaner/polish to the synthetic, abrasive pads and CAREFULLY rub out spot with cleaner/polish. *Be sure to rub in the direction of the grain!* Do not allow steel wool to come in contact with stainless steel. Steel particles can embed into the stainless steel surface and create rust!

Special Note:

After cleaning for serious problems, let dry, and expose to air for at least 24 hours to allow “healing” (restoring of the chromium oxide layer) of the stainless steel surface.

THINGS TO AVOID:

- Harsh polishing cleanser (Comet, Bon Ami, etc.)
- Harsh chemicals (strong acidic or alkaline materials such as hydrochloric acid, sodium hydroxide, etc.)
- Any abrasive substance (dirt/mud, ceramic items, etc.)
- Chlorinated cleansers, sanitizers or bleach of any kind
- Steel wool, steel utensils or any object made of steel or metal, left in contact with stainless surface (hair pins, paper clips, aerosol cans)
- Scotch-Brite® type pads on high-polished surfaces
- Seawater or excessively hard water
- Salt or salty foods allowed to dry on surface
- Leaving scratches in metal surface (soil can collect in these, preventing surface from “healing”)
- Leaving hard water sitting (evaporating) for extended periods, allowing mineral deposits to collect

LIMITED WARRANTY

NEO-METRO warrants that its' products are free from defects in material or workmanship under normal use and service for a period of one year from date of shipment. NEO-METRO's liability under this warranty shall be discharged solely by replacement or repair of defective material, provided NEO-METRO is notified in writing within one year from date of shipment, F.O.B. Industry, California.

This warranty does not cover installation or labor charges, and does not apply to materials, which have been damaged by other causes such as mishandling or improper care or abnormal use. The repair or replacement of the defective materials shall constitute the sole remedy of the Buyer and the sole remedy of NEO-METRO under this warranty. NEO-METRO shall not be liable under any circumstances for incidental, consequential or direct charges caused by defects in the materials, or any delay in the repair or replacement thereof. This warranty is in lieu of all other warranties expressed or implied. Product maintenance instructions are issued with each fixture and disregard or non-compliance with these instructions will constitute an abnormal use condition and void the warranty. Stainless steel must be protected on jobsites during construction and must be properly maintained after the water has been introduced into the fixture, or NEO-METRO's limited warranty is void. If you have any questions regarding technical assistance please call 800-743-8259.

Return Goods Authorization:

No materials shall be returned without a Return Goods Authorization (RGA) from NEO-METRO Customer Service. Returns must reference the RGA number and be shipped freight prepaid or the shipment will not be accepted. Credit issued for the return will apply only to future shipments and will be subject to a **25% handling charge**. Any cost associated with restoring product to saleable condition will be deducted from the credit. **Non-stock and custom fabrications are non-returnable.** RGA credit will not be issued for less than \$100.00 unless material is proven defective.

Claims and Shortages:

F.O.B. factory shipments are the full responsibility of the Buyer. Losses or damages must be reported to the carrier immediately. NEO-METRO will file freight claims on FFA orders if the Buyer complies with the following within (5) five days of receipt of shipment: inspect shipment immediately, have delivering carrier inspect shipment, file inspection report with carrier, and send a copy to NEO-METRO. No claim for failure to receive shipment or shortage will be honored unless NEO-METRO is notified immediately upon receipt of invoice or within five working days of receipt of shipment, whichever is sooner.

Visit our web site at: www.neo-metro.com for our General Terms and Conditions of Sale.