

**NOTE:**

SOME AVAILABLE OPTIONS FOR THIS UNIT MAY ALTER THESE ROUGH-IN INSTRUCTIONS. CONTACT FACTORY FOR DETAILS.

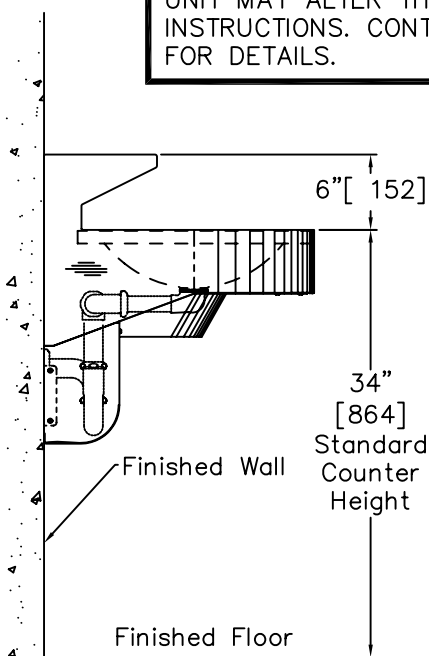

**SIDE VIEW**

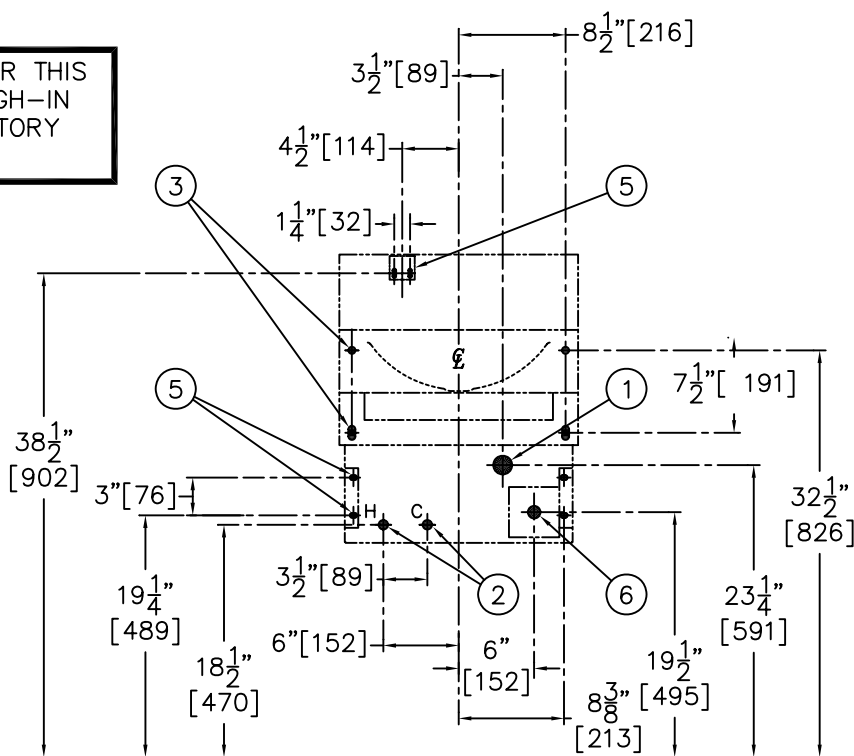

**FRONT VIEW**

**ROUGH-IN FOR THE FOLLOWING:**

- 1- LAVY WASTE OUTLET - 1-1/2" O.D. TUBE FOR COMPRESSION JOINT.
- 2- MIXING VALVE INLET - 1/2" NPS HOT AND COLD VALVE SUPPLIES.
- 3- MOUNTING LOCATIONS - 9/16" DIAMETER MOUNTING HOLES (2) PLACES, 9/16" x 1-1/8" SLOTS (2) PLACES.
- 4- TRAP COVER MOUNTING - (2) MOUNTING BRACKETS. EACH BRACKET HAS (2) 3/8" x 9/16" SLOTS FOR FASTENERS.
- 5- -IS (INTEGRAL SHELF) MOUNTING - (1) "S" TYPE MOUNTING CLIPS WITH (2) 9/32" x 3/4" SLOTS FOR FASTENERS.
- 6- FOR -SO SENSOR OPERATED CONTROLS. PROVIDE 120V/60Hz/3 AMPS(MAX.) ELECTRIC RECEPTACLE TO CONNECT FACTORY SUPPLIED 120 VAC TO 9VDC 100 mA PLUG-IN TRANSFORMER. NOTE: RECEPTACLE MUST BE WIRED TO A GFI PROTECTED CIRCUIT. FIXTURE MUST BE EARTH GROUNDED PER N.E.C. (NATIONAL ELECTRICAL CODE).

**INSTALLATION INSTRUCTIONS:**

UNIT IS INTENDED FOR INSTALLATION ON A FINISHED WALL WITH APPROPRIATE WALL BACKING. 3/8" UNC WALL ANCHORS AND HARDWARE ARE NOT PROVIDED.

UNIT INCLUDES WASTE PIPING AND 1-1/2" TUBULAR P-TRAP. VALVE ASSEMBLY SHIPPED LOOSE FOR MOUNTING TO WALL. INCLUDES VALVE AND TRAP ENCLOSURE, SHIPPED LOOSE. VALVE INCLUDES 1/2" STAINLESS FLEX CONNECTION.

|                                                                                                         |                                                                      |                                       |                                                  |
|---------------------------------------------------------------------------------------------------------|----------------------------------------------------------------------|---------------------------------------|--------------------------------------------------|
| <br>WWW.NEO-METRO.COM | <b>TITLE</b> <b>ROUGH-INS #8980-1-IS (INTEGRAL SHELF) SYSTEM M-2</b> |                                       |                                                  |
|                                                                                                         | <b>MANUFACTURE DATE</b><br><b>MARCH 2008</b><br><b>TO PRESENT</b>    | <b>DATE ISSUED</b><br><b>03/28/08</b> | <b>DRAWING NUMBER</b><br><br><b>9935-402-001</b> |
|                                                                                                         | <b>DATE REVISED</b><br><b>03/16/09</b>                               |                                       |                                                  |