

Geberit Installation System for Wall-Hung Toilets, Pre-Wall Installations

Product Specifications

In-Wall Duofix carrier system and concealed tank with actuator flush panel or pneumatic push button for washdown wall-hung toilets. System shall fit within minimum 6¾" (170 mm) framing wall or plumbing chase, with wood construction or steel framing members placed 19¾" (500 mm) apart. Framing members should be capable of supporting a 880 pound (400 kg) load without damage to the wall. Water supply shall have flow diameter no smaller than 1/2" (13 mm) copper tube, and a minimum flow pressure of 2 PSI (0.01 MPa). The toilet bowl shall be a third party listed low-consumption 1.6 GPF (6 LPF) or 1.6/0.8 GPF (6/3 LPF) dual-flush 2-hole wall-hung type. The carrier frame shall be adjustable for bowl rim heights from 15" to 19" (381 to 483 mm). Actuator flush panels shall be diecast zinc, molded plastic or fabricated stainless steel and plated to preserve material integrity. All components shall be compliant with applicable codes and product standards.

Warranty

Limited lifetime warranty on tank and carrier, 10-year warranty on fill valve and flush valve. One-year warranty on actuator flush plates.

Features

- Water consumption – Dual-flush system allows 1.6/0.8 GPF (6/3 LPF), giving effective flush volume of 1.1 GPF (4 LPF)
- Anti-siphon fill valve
- Impact resistant high density polyethylene (HDPE) tank, insulated to prevent condensation
- 16-gauge, powder-coated, structural-steel tubing rated to 880 lbs. (400 kg) without damage to finished wall or carrier unit
- Bowl rim height adjustments from 15" to 19" (381 to 483 mm)
- 32½" (820 mm) frame height
- For finished walls up to 3½" (9cm) thick
- Small inspection opening for Kappa flush actuator plates
- Includes installation and rough-in materials

Complies with the latest editions of:

- ASME: A112.6.2, A112.19.5, A112.19.14
- ANSI Z124.4
- CSA B125.3
- ANSI/ASSE 1002
- IAPMO PS-50
- UNAR / UNAR-HET
- ASME A112.19.2
- This concealed tank is WaterSense® compliant when used in combination with the toilet bowl models listed on page 2 of this sheet.
- State of Massachusetts listed

Model No.	Description
111.255.00.1	Geberit Duofix Carrier with Kappa Concealed Tank, pre-wall installations for wall-hung toilets

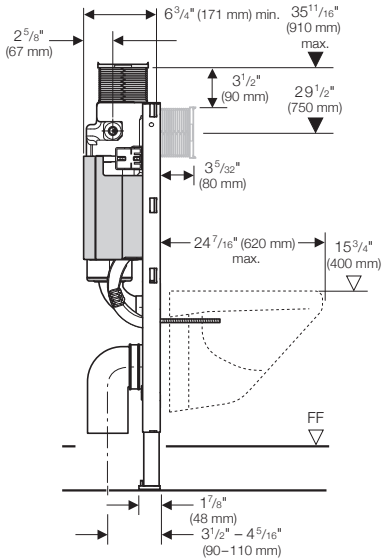
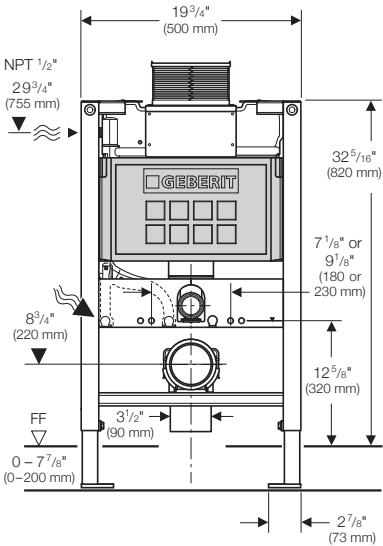

ARCHITECT/ENGINEER APPROVAL	
Job Name	_____
Date	Quantity _____
Model Specified	_____
Variations Specified	_____
Customer/Wholesaler	_____
Contractor	_____
Architect	_____

Geberit Installation System for Wall-Hung Toilets, Pre-Wall Installations



WaterSense EPA High Efficiency Compatible Wall-hung Toilet Bowl Models

Brand Name	Model No.*	Model Name
Duravit	221709	Vero
TOTO	CT418FG	Aquia
	CT486FG	Maris

Note: Tank model numbers may have suffix xx.x, where xx.x

denotes shipping information.

*Consult toilet manufacturers for up-to-date model numbers and availability.

Other Compatible Wall-hung Toilet Bowl Models

Brand Name	Model No.*	Model Name
Blu	LW6008	Coco
Bathworks	LW6020	Metrix
Duravit	220509	2nd Floor
	222009	2nd Floor
	15609	Caro
	220909	D-Code
	222309	D-Code elongated
	20709	Darling
	254409	Darling New elongated
	255409	Esplanade
	17509	Bathroom_Foster
	17109	Happy D
	221909	PuraVida
	16009	Starck 2
	253309	Starck 2 elongated
	220009	Starck 3
	220209	Starck 3 compact
	220309	Starck 3 extra long
	222609	Starck 3 elongated
	220409	Starck X
	221709	Vero
Brand Name	Model No.*	Model Name
Icera	C-2340	Metro
	C-6610	Clarity elongated
Kohler	K-6299	Veil
Lacava	5458	Aquagrande
	4278	Piazza
	6058	Suave
	2958	Tre
Laufen	8.2090.0	Alessi d0t
	8.2090.8	Alessi d0t
	8.2097.8	Alessi One
	8.2067.1	Form
	8.2097.6	Alessi One
	8.2095.0	Laufen Pro
	8.2095.6	Laufen Pro
	8.2095.2	Laufen Pro Compact
	8.2068.0	LB3
	8.2043.5	Living City
	8.2055.0	Mimo
	8.2094.6	Mylife
	8.2094.8	Mylife
	8.2070.8	Palace
	8.2080.1	Palomba

Brand Name	Model No.*	Model Name
Mirabelle	MIRE220WH	Edenton
	MIRWH220WH	Winter Haven
Neo-Metro	8951	Euro-Urban Contour
	8957	Metaal
	8952	miniLoo
Brand Name	Model No.*	Model Name
Porcher	47010-11	Solutions
ROCA	346768	Armani
	346518	Dama Senso
	346468	Giralda
	346628	Hall
	346568	Happening
TOTO	CT418FG	Aquia
	CT486FG	Maris
Villeroy & Boch	6612-XX-XX	Aveo
	5664-XX-XX	Bellevue
	6653-XX-XX	Century
	6665-XX-XX	Editorials
	6661-XX-XX	Hommage
	5627-XX-XX	La Belle
	7631-XX-XX	Magnum
	5628-XX-XX	Memento
	6664-XX-XX	Oblic
	5684-XX-XX	Omnia
	5674-XX-XX	Omnia Architectura
	5678-XX-XX	Omnia Architectura Vita
	5670-XX-XX	Pure Stone
	5622-XX-XX	Sentique
	6661-XX-XX	Strada
	6600-XX-XX	Subway

Geberit
2100 S. Clearwater Drive
Des Plaines, IL 60018
USA

P 800-566-2100
F 847-803-5454

→ geberit.us

© 2013 Geberit. Product specifications subject to change without notice.

GNA7011 04/13